



PQ Tech

Power Quality Specialist

D1001 Digital Empire, 980-3, Yeongtong-dong, Yeongtong-gu,
Suwon, 443813 Gyeonggi-do, Republic of Korea

TEL. +82(0)31-303-5530-3 FAX. +82(0)31-303-5535

<http://www.pqtech.co.kr>



- Active Harmonic Filters
- Reactive Var Compensators
- Sag Compensators

Power Quality Solutions Manufacturer



I About Us

Established in 2000, PQ Tech is the leading company specializing in providing power quality solutions for utility and industry customers to improve their performance with less impact on the environment. PQ Tech's technology plays a key role in the rapid growth of our product development. PQ Tech provides services to manufacturing, system diagnosis, construction, and the operation industry with commercial applications.

In Korea, PQ Tech was the first company to install the 22.9kV, 90[ton] EAF Harmonic Filter Bank nationwide. PQ Tech handles huge turnkey-based projects for large domestic customers and various international customers.

PQ Tech commercialized and supplied a harmonic filter to Samsung Electronics, government offices, and many more by replacing imported products with in-house development products. In addition, PQ Tech's harmonic filter was granted the excellent product certification by the Supply Administration and the Agency for Technology and Standards (SAATS), as well as ISO 9001. With highly qualified professional manpower in our research institute, we have streamlined the upcoming technology in development and have increased efficiency with eight registered patents for active power filters and other products. Also, PQ Tech has obtained the trademark for HHF and other products, playing a significant role in the excellent advancement of the nation's technology.

I Certifications

Patents by the Korea Intellectual Property Office

1. Advanced Hybrid Harmonic Filters
2. Intelligent Power Quality Filter-Single Phase
3. Advanced Zero Sequence Harmonic Filter
4. Linear 3P4W Reactive Power Compensator
5. Magnetic Shielding Air Core Reactor
6. 3P4W Active Power Filter Control Device
7. The Harmonic Reduction Apparatus
by using Zero-Phase-Sequence-Impedance
8. Hybrid Harmonic Filter

New Excellent Product(NEP) by the Ministry Knowledge Economy Republic of Korea

1. Digital Controlled 3Phase 4Wire Active Power Filter
2. Digital Single Phase Active Power Filter
3. 3Phase Reactor Applied Harmonics Filter

Excellent Product by the Public Procurement Service of Korea

Hybrid Harmonic Filter

Quality Management Systems

ISO 9001:2000 Design, Development, Production and Servicing of Harmonic Filter
by the Korea Testing Laboratory

Venture Business

Venture Business by the Small & Medium Business Administration

INNO-BIZ

Innovation Business by the Small & Medium Business Administration

Promising Enterprise

Promising Small & Medium-sized Enterprise
by the Gyeonggi Provincial Government

Excellent Quality

Excellent Quality by the Government Supply Administration

Superior Technology Company

Superior Technology Company
by the Korea Technology Credit Guarantee Fund

Power Quality & Energy Total Solution Provider

Active Harmonic Filters

(IPF series - Intelligent Power Quality Filters)

High Filtering Efficiency, Reduced Noise and Temperature Rise

- IPF3 - 3phase 3wire load system
- IPF4 - 3phase 4wire load system

Single Phase Active Harmonic Filters

(SPC series - Smart Power Conditioners)

High Filtering Efficiency, Easy Extension with 19inch standard rack

- SPC - Single phase load on 3phase system

Reactive Var Compensators

(IVC series - Intelligent Var Compensators)

16 step combinationed operation, Longer life

- IVC - 2Phase load system

Sag Compensators

(SSC series - Smart Sag Compensators)

Fast in action, High Efficiency, No Batteries

- SSC - Individual Single phase loads on 3phase system



C O N T E N T S

IPF Intelligent Power Quality Filter	_ 06
SPC Smart Power Conditioner	_ 11
IVC Intelligent Var Compensator	_ 14
SSC Smart Sag Compensator	_ 16
PSE Power System Engineering	_ 19



IPF Intelligent Power Quality Filter



Active Harmonic Filters

High Filtering Efficiency, Reduced Noise and Temperature Rise

Outline

Harmonic distortion and power Quality

The proliferation of nonlinear loads such as static power converters and arc furnaces results in a variety of undesirable phenomena in the operation of power systems. The most important among these are harmonic contamination, increased reactive power demand, and power system voltage fluctuations. Harmonic currents increase power systems losses, excessive heating in rotating machinery, and can create significant interference with the power line communication. The harmonics are a growing problem for both electricity suppliers and consumers.

Problems caused by harmonics

- Malfunction of precision control
- Capacitor overloading and failures
- High current in neutral conductors
- Excitation of network resonance
- Damage to sensitive equipment
- Overheating of transformer, motor and cables
- Frequent tripping of circuit breakers

Features

Intelligent Power Quality Filter (IPF)

PQ Tech offers a compact, cost-effective, and completely integrated system solution for the growing number of applications.

The IPF offers the ability to eliminate the network harmonics from the supply source.

- Patent No.0459000 as a Three Phase fourwire active power filter control device
- Following IEEE Std.519-1992
- Solution against Power Quality Problems
- Parallel connection allowing easy retrofit for large systems
- Curtailment of maintenance fee



[3P Active Harmonic Filter]

IPF3

- 3 Phase 3 wire load system

System

- 70~1000A
- 380~440V
- 50/60Hz

Application

- Industrial
- Selectable harmonic compensation
- Intelligent harmonic current prediction
- Filtering up to 50th Harmonic
- Harmonic attenuation factor around 98%
- Easy commissioning
- Reactive power compensation
- Phase/Load balancing
- Power factor control
- Not required any special current transformers
- User-friendly Graphical User Interface with LCD
- Remote-based control of MMI Interface with graphical-based environment
- RS232 communication compatible
- Fault and event logging in real-time
- Advanced Modulation technology to reduce ultra-low harmonic distortion

IPF4

- 3 Phase 4 wire load system

System

- 70~1000A
- 380~440V
- 50/60Hz

Application

- Commercial
- Selectable harmonic compensation
- Zero sequence harmonic compensation
- Neutral current compensation
- LCL-based filter configuration
- Filtering up to 50th Harmonic
- Harmonic attenuation factor is 98%
- Reactive power compensation
- Phase/Load balancing
- Power factor control
- User friendly Graphical User Interface with LCD
- Remote-based control of MMI Interface with graphical-based environment
- RS232 communication compatible
- Fault and event logging in real-time
- Advanced Modulation technology to reduce ultra-low harmonic distortion

Operation of IPF

To Compensate Load Harmonics supplied by a source, IPF is connected to grid system.

IPF3

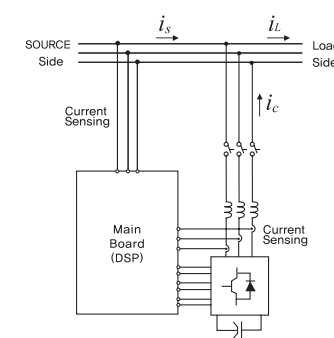

IPF4

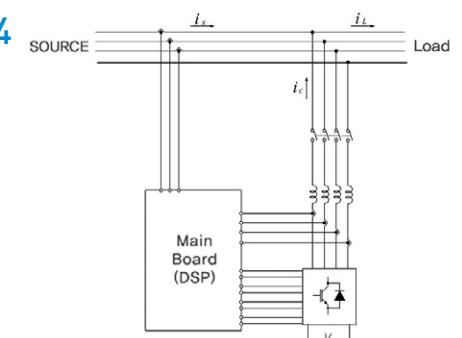



Application Case - IPF3

Application Case - IPF4

Filter Running

Unfiltered Source Current

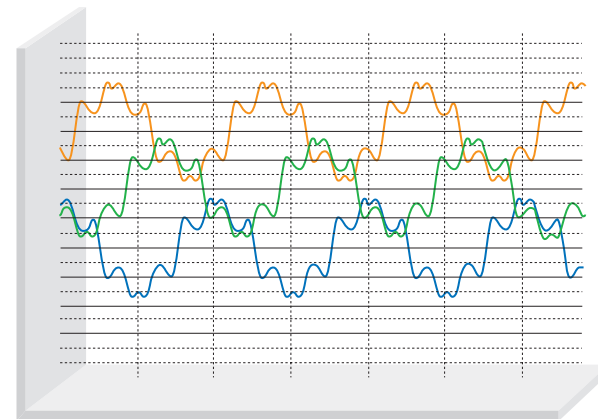

CH1-3 : 25.00 A/div — CH1 — CH2 — CH3

Filtered Source Current

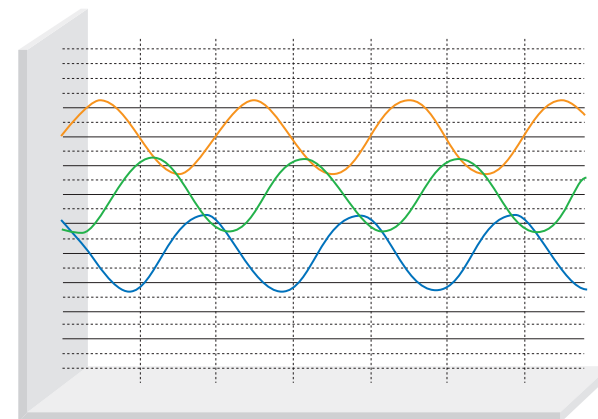

CH1-3 : 25.00 A/div — CH1 — CH2 — CH3

Power		Voltage		Current	
Freq	60.001Hz				
P1	9.286kW	U1	211.65V	I1	52.92A
P2	9.281kW	U2	212.65V	I2	52.68A
P3	9.450kW	U3	212.45V	I3	53.39A
Psum	28.02kW	THD-U1	3.90%	THD-I1	29.59%
S1	11.200kVA	THD-U2	3.97%	THD-I2	29.85%
S2	11.203kVA	THD-U3	3.91%	THD-I3	29.82%
S3	11.342kVA	Upk+1	0.3106kV	Ipk+1	83.89A
Ssum	33.75kVA	Upk+2	0.3127kV	Ipk+2	83.49A
Q1	6.261kvar	Upk+3	0.3109kV	Ipk+3	85.42A
Q2	6.275kvar	Upk-1	-0.3101kV	Ipk-1	-83.91A
Q3	6.273kvar	Upk-2	-0.3129kV	Ipk-2	-83.51A
Qsum	18.81kvar	Upk-3	-0.3113kV	Ipk-3	-85.20A
PF1	0.8291	Uave	212.25V	KF1	4.06
PF2	0.8284	Uunb	0.28%	KF2	4.11
PF3	0.8331			KF3	4.12
PFsum	0.8302			lave	53.00A
				lunb	0.46%

Power		Voltage		Current	
Freq	59.995Hz				
P1	9.548kW	U1	214.13V	I1	44.69A
P2	9.749kW	U2	215.04V	I2	45.47A
P3	9.805kW	U3	215.00V	I3	45.69A
Psum	29.10kW	THD-U1	1.92%	THD-I1	2.80%
S1	9.570kVA	THD-U2	1.83%	THD-I2	3.97%
S2	9.777kVA	THD-U3	1.56%	THD-I3	4.46%
S3	9.824kVA	Upk+1	0.3152kV	Ipk+1	63.59A
Ssum	29.17kVA	Upk+2	0.3200kV	Ipk+2	65.04A
Q1	-0.656kvar	Upk+3	0.3175kV	Ipk+3	67.34A
Q2	-0.749kvar	Upk-1	-0.3148kV	Ipk-1	-63.67A
Q3	-0.603kvar	Upk-2	-0.3196kV	Ipk-2	-64.78A
Qsum	-2.01kvar	Upk-3	-0.3167kV	Ipk-3	-68.77A
PF1	-0.9976	Uave	214.72V	KF1	1.08
PF2	-0.9971	Uunb	0.25%	KF2	1.09
PF3	-0.9981			KF3	1.08
PFsum	-0.9976			lave	45.28A
				lunb	1.53%

Filter Running

Unfiltered Source Current

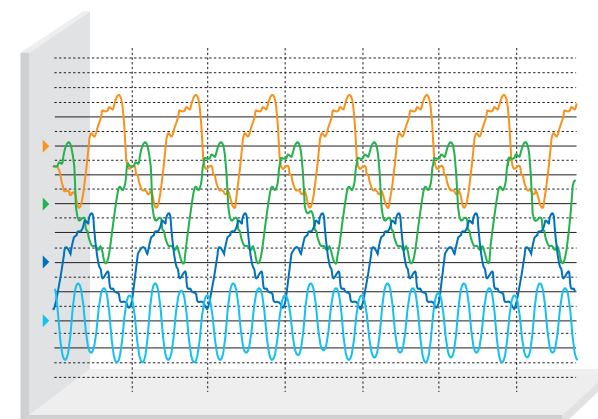

CH1-3 : 125.00 A/div CH4 : 125.00 A/div
— CH1 — CH2 — CH3 — CH4

Power		Voltage		Current	
Freq	59.968 Hz				
P1	66.51 kW	U1	224.62 V	I1	320.39 A
P2	67.93 kW	U2	230.95 V	I2	322.34 A
P3	55.35 kW	U3	229.24 V	I3	263.56 A
Psum	0.1898 kW	U4	15.99 V	I4	223.69 A
S1	71.96 kVA	THD-U1	14.00 %	THD-I1	30.21 %
S2	74.45 kVA	THD-U2	13.07 %	THD-I2	34.22 %
S3	60.42 kVA	THD-U3	11.93 %	THD-I3	29.74 %
Ssum	0.2068 kVA	THD-U4	99.07 %	THD-I4	97.12 %
Q1	-27.48 kvar	Upk+1	0.2809 V	Ipk+1	0.5018 A
Q2	-30.46 kvar	Upk+2	0.2890 V	Ipk+2	0.5369 A
Q3	-24.24 kvar	Upk+3	0.2900 V	Ipk+3	0.4189 A
Qsum	-0.0822 kvar	Upk+4	0.0297 V	Ipk+4	0.3529 A
PF1	-0.9242	Upk-1	-0.2802 V	Ipk-1	-0.4962 A
PF2	-0.9125	Upk-2	-0.2876 V	Ipk-2	-0.5279 A
PF3	-0.9160	Upk-3	-0.2886 V	Ipk-3	-0.4158 A
PFsum	-0.9176	Upk-4	-0.0286 V	Ipk-4	-0.3487 A
		Uave	228.27 V	KF1	2.62
		Uunb	0.95 %	KF2	2.86
				KF3	2.52
				KF4	8.72
				lave	302.10 A
				lunb	6.10 %

Filtered Source Current

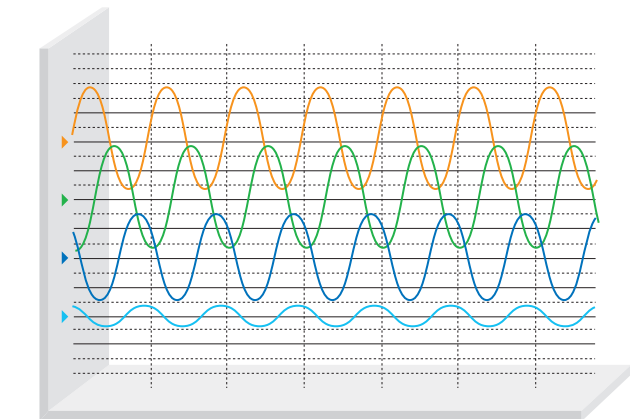

CH1-3 : 125.00 A/div CH4 : 125.00 A/div
— CH1 — CH2 — CH3 — CH4

Power		Voltage		Current	
Freq	59.940 Hz				
P1	67.18 kW	U1	223.25 V	I1	316.22 A
P2	69.33 kW	U2	230.05 V	I2	315.32 A
P3	56.17 kW	U3	228.38 V	I3	260.56 A
Psum	0.1927 kW	U4	7.48 V	I4	58.57 A
S1	70.59 kVA	THD-U1	4.70 %	THD-I1	0.77 %
S2	72.54 kVA	THD-U2	4.66 %	THD-I2	1.38 %
S3	59.51 kVA	THD-U3	4.63 %	THD-I3	1.30 %
Ssum	0.2026 kVA	THD-U4	95.38 %	THD-I4	6.99 %
Q1	-21.70 kvar	Upk+1	0.2984 V	Ipk+1	0.4464 A
Q2	-21.33 kvar	Upk+2	0.3091 V	Ipk+2	0.4439 A
Q3	-19.65 kvar	Upk+3	0.3077 V	Ipk+3	0.3707 A
Qsum	-0.0627 kvar	Upk+4	0.0136 V	Ipk+4	0.0904 A
PF1	-0.9516	Upk-1	-0.2981 V	Ipk-1	-0.4481 A
PF2	-0.9558	Upk-2	-0.3075 V	Ipk-2	-0.4493 A
PF3	-0.9439	Upk-3	-0.3071 V	Ipk-3	-0.3710 A
PFsum	-0.9508	Upk-4	-0.0126 V	Ipk-4	-0.0873 A
		Uave	227.23 V	KF1	1.01
		Uunb	0.94%	KF2	1.02
				KF3	1.02
				KF4	1.22
				lave	297.36 A
				lunb	6.17 %



IPF Intelligent Power Quality Filter

IPF Manager of IPF

Operator can control and view the operation of IPF with user-friendly graphical interface on LCD of IPF Panel.

- Keypad interface to configure IPF filter
- Monitoring of filter behavior and components
- Measurements of system variables
- Event log recording
- Network status monitoring
- Protection from malfunction
- Parameter settings and operator settings
- Waveforms in graphical display

Man Machine Interface of IPF

- Remote control from PC (Personal Computer)
- Windows-based graphical user interface
- High functionality
- Same menu structure as key pad interface with some additional features

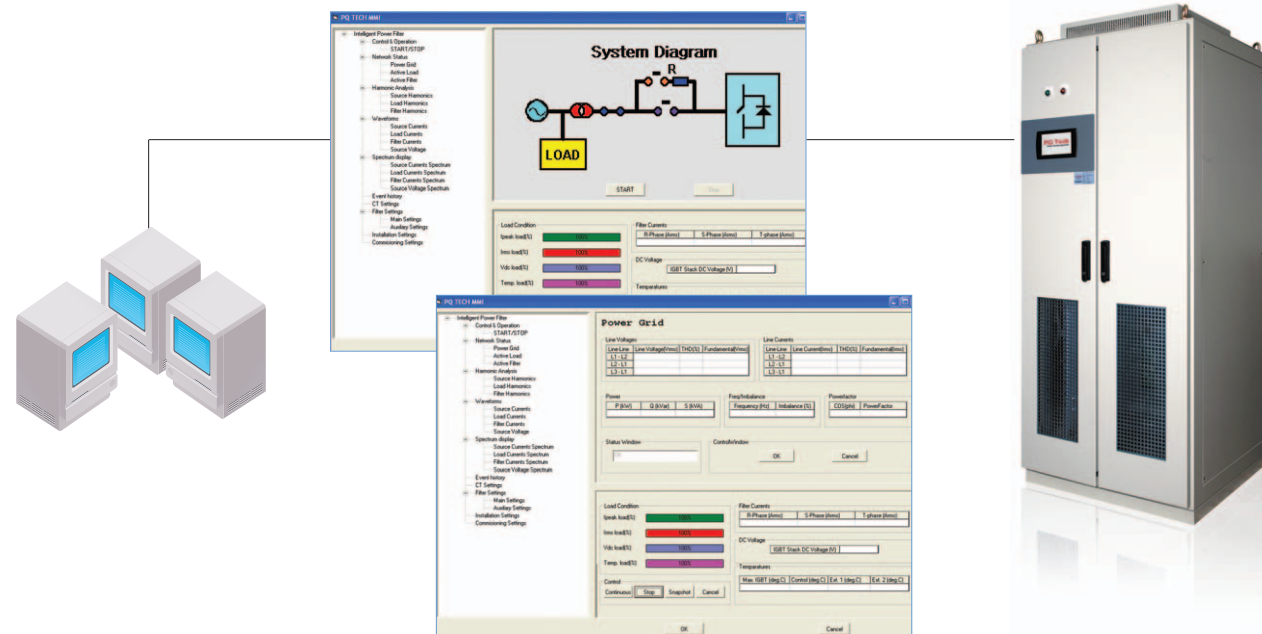

Drawing

Dimensions of IPF

Type	Rating Current[A]	Outer Dimensions[mm]		
		W	D	H
IPF3-□□ 100	100	800	800	2250
IPF3-□□ 200	200	800	800	2250
IPF3-□□ 300	300	800	800	2250
IPF4-□□ 100	100	800	800	2250
IPF4-□□ 200	200	800	800	2250
IPF4-□□ 300	300	800	800	2250

Note - Higher capacity can be available with parallel configuration dimensions that can be changed without notice.
□□ - Voltage ratings, ex : 380 V-38, 440 V- 44



SPC Smart Power Conditioner



SPC Smart Power Conditioner



Single Phase Active Harmonic Filters

High Filtering Efficiency, Easy Extension with 19inch standard rack



[1P Active Power Filter]

Outline

The increase in nonlinear loads such as computer servers, power supplies, and electronic ballasts results in a variety of undesirable phenomena in the operation of power systems. The most important among these are harmonic contamination, voltage distortion, and power system voltage fluctuations. Harmonic voltage components cause rebooting, power system losses, errors, excessive heating of the machine, and can create significant interference on the communication line. The SPC can monitor and control the active condition of single phase nonlinear loads like a data bank, UPS, and IT server in real-time. Therefore, the SPC can keep up the best power quality of the network that corresponds to a limitation of IEEE Std. 519, AS-2279, EN61000-3-4 and BS G5/4.

Features

- Patent No.0766718 as a Single Phase active power filter control device for single phase nonlinear loads
- Following IEEE Std.519-1992
- Solution against Power Quality Problems
- Parallel connection allowing easy retrofit for large systems
- Eliminates neutral zero sequence harmonic current
- Modular unit and rack mount expansion

Benefits

- Solution against a power quality problems
 - Reduction of harmonic distortion
 - Reduction of peak line current
 - Reduction of loss in distribution line
 - Overheating prevention in neutral line
 - Prevention of the interference and loss of data in information transmission equipment
 - Prevention of the damage to power sensitive user equipment
- Prevention of the misoperations of the breaker
- Guarantee of the safety of the power system and reduce cost
- Easy to expand the capacity; simple addition of module to expand the capacity
- Compact design and monitoring of the power quality
- Selective control for harmonics

Applications

Loads

Computer server, SMPS, Inverter, UPS, IT equipment, etc.

Systems

Three phase four wire, Single phase 120V-400V, 30~300A

Locations

Large computer server center, Data bank, Office, Apartment, Airport, Hospital, etc.



Operation

The SPC is a single-phase active power filter, which is applied to the statistical operation and method of current injection by using DSP. SPC is composed of a breaker, power fuse, surge protection circuit, sinusoid filter, capacitor and DSP controller. The DSP controller monitors a power of non-linear load in real-time, estimates the load current harmonics, then, using IGBT switching devices, injects out of phase current component into the power system. After the SPC filter is in operation, the voltage and current waveforms of the power system become a pure sinusoidal wave.

System Configurations

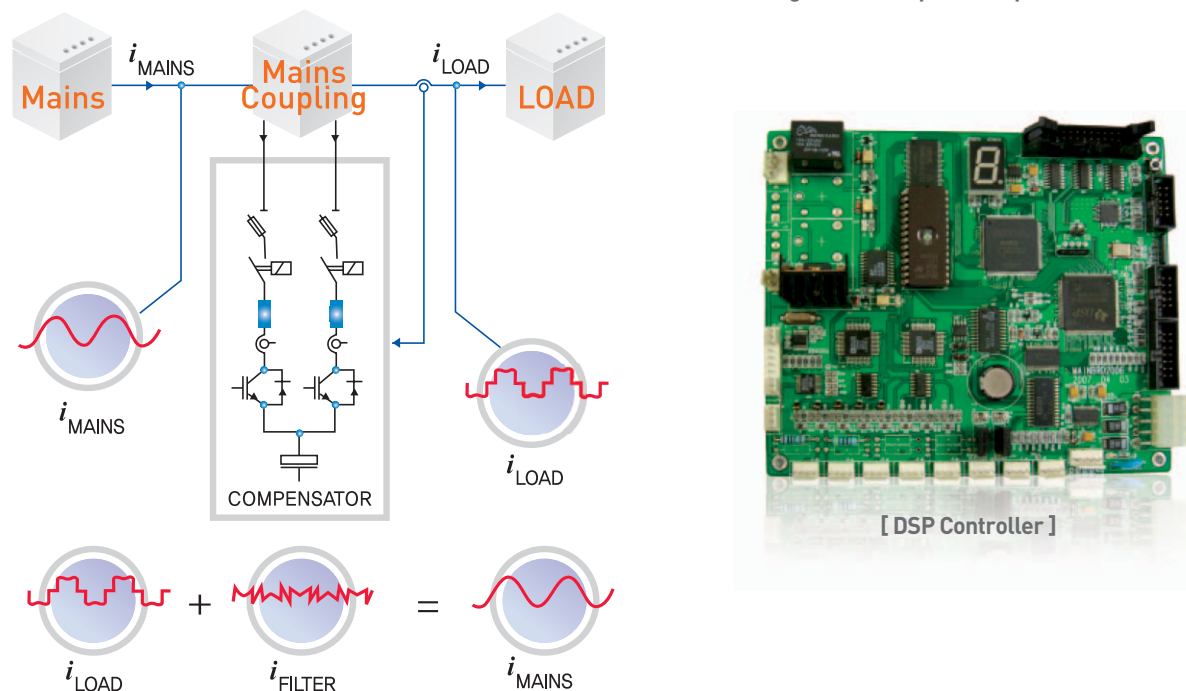
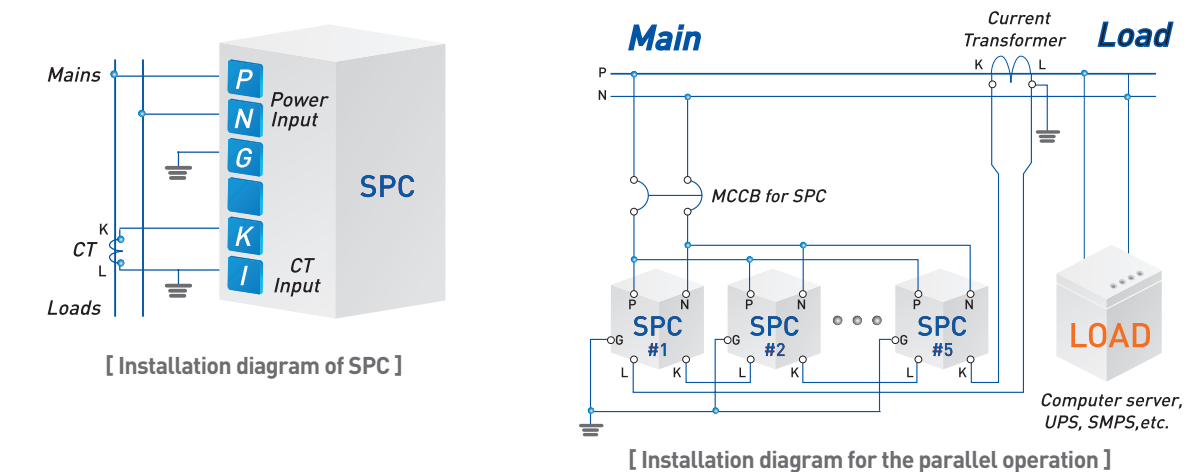

Installation Effects

- Operation near unity power factor
- ITDD less than 5%
- Elimination of the neutral zero sequence harmonic current
- Prevention of the flicker and surge
- Prevention of the misoperations of server and UPS
- Prevention of the heating and damage of neutral cable
- Prevention of the damage to breaker, fuse, reactor, capacitor
- Sensitive equipment protection against noise
- Increasing the capability of the transformers
- Reduction of the system loss
- Minimizing the interference with other equipment

Dimensions of SPC

Type	SPC 15	SPC 30
Rating Current(A)	15	30
Dimensions (mm)	W	483
	D	420
	H	220

[Modular expansion 500 Amax]

Application Case

Unfiltered Source Current



[CH1: 50.00A/div]

Filtered Source Current

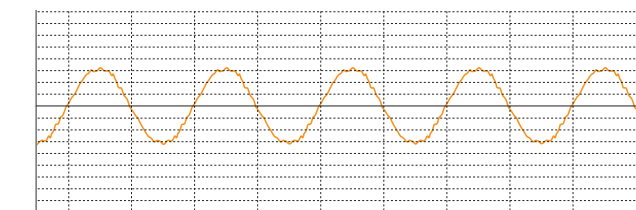

[CH1: 50.00A/div]

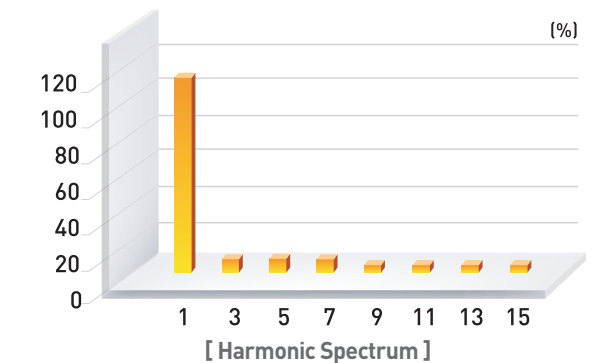
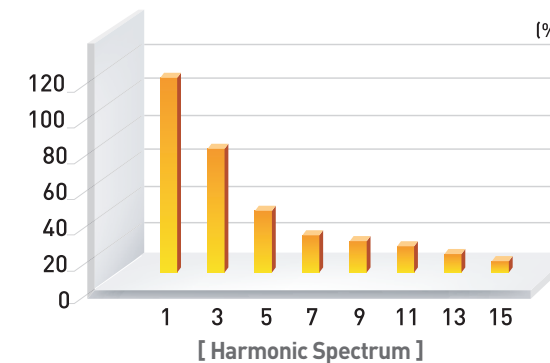

	Power	Voltage	Current
Freq	59.988Hz		
P1	24.28kW	U1 224.39V	I1 128.74A
S1	28.89kVA	THD-U1 7.08%	THD-I1 53.74%
Q1	-15.64kvar	Upk+1 295.90V	Ipk+1 0.2677kA
PF1	-0.8407	Upk-1 -295.61V	Ipk-1 -0.2669kA
			KF1 5.67

	Power	Voltage	Current
Freq	59.955Hz		
P1	25.00kW	U1 226.07V	I1 111.53A
S1	25.21kVA	THD-U1 4.07%	THD-I1 4.29%
Q1	-3.28kvar	Upk+1 306.36V	Ipk+1 0.1621kA
PF1	-0.9915	Upk-1 -306.43V	Ipk-1 -0.1594kA
			KF1 1.40



IVC Intelligent Var Compensator



Reactive Var Compensators

16 step combination operation, Longer life

Outline

The rapid growth of non-linear loads, such as large capacity welding machines, cranes, and adjustable speed drives(ASDs), draws a large reactive power from the source supply and results in high voltage fluctuation and flicker in the system, which has an adverse effect on electric and control unit of the system IVC (Intelligent Var Compensator) and compensates for the reactive power drawn by the load from the power system.

IVC is a DSP-based controlled power electronics system that compensates reactive power in real-time, stabilizes the voltage, and reduces the flicker and power factor improvement.

Features

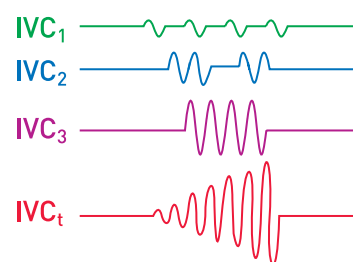
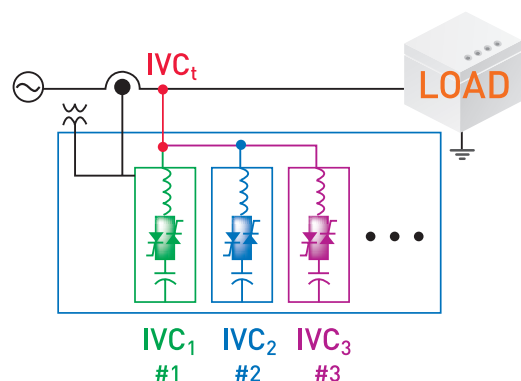

[IVC single line diagram and the reactive power compensation current wave]

- Patent No.0435620 as 3 phase 4-wire reactive power compensation system with linear response characteristics
- Response time : 5~16ms
- Prevention of the flicker
- Transient free
- Free from excessive switching phenomenon
- Energy efficiency improvement
- Electronic devices protection
- Life cycle expansion of the equipments
- Easy to expand the capacity; simple addition of module to expand the capacity
- Harmonic filter function (optional)
- Load balancing (optional)

Applications

Loads

Irregular reactive power-generating load and flicker generating loads, such as welding machine, adjustable speed drives, crane, etc.

System ratings

380V/440V, 30~1800kVAR, rated frequency 50/60Hz, rated circuit 3P3W/3P4W

Application areas

Steel plant, chemical plant, shipbuilding yard (dockyard), commercial plant

Principle of operation of intelligent reactive power compensator (IVC)

- Zero voltage control through thyristor, minimizing excessive phenomenon.
- Applicable to short-time load-based on rapid response control, such as welding machines and lifts
- Harmonic wave filter function(optional)

Effects

- Power factor on the secondary side of transformer can be kept at 98% on the average
- Average current can be reduced by 30%
- Allowance capacity of transformer can be kept at 30%
- Reactive power can be resolved in real-time, which minimizes the voltage flicker no matter how high the simultaneous performance rate of the load is.

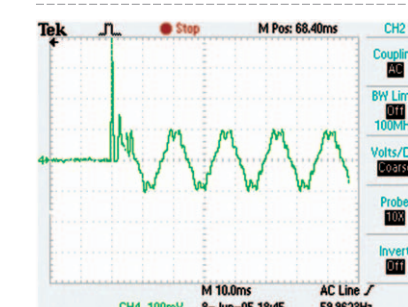

[Input of the existing APEC condenser]

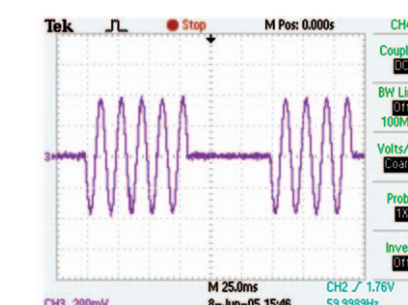

[Input of the IVC condenser]

Drawing

Dimensions of IVC

Type	Output (kVAR)	Rating Step (kVAR)	Ratio	Outer dimensions (mm)		
				W	D	H
IVC 38090	90	30	1:1:1	800	800	2000
IVC 38120	120	30	1:1:1:1	800	800	2000
IVC 38150	150	30	1:2:2	800	800	2000
IVC 38180	180	60	1:1:1	800	800	2000
IVC 38210	210	30	1:2:2:2	800	800	2000
IVC 38240	240	60	1:1:1:1	800	800	2000
IVC 38250	250	50	1:2:2	800	800	2000
IVC 38270	270	30	1:2:2:4	800	800	2000
IVC 38300	300	100	1:1:1	800	800	2000
IVC 38350	350	50	1:2:2:2	1600	800	2000
IVC 38400	400	100	1:1:1:1	1600	800	2000



SSC Smart Sag Compensator

Sag Compensator
Fast Reaction, High Efficiency, No Batteries

Outline

The SSCs are cutting-edge technology products developed to keep power supply in optimum condition. In real-time, the SSCs monitor and control the power supply of single-phase precise load of servers, automation equipments, medical equipments, semiconductor equipment, etc. SSC can be used to prevent from rebooting, data loss, and malfunction of the equipments due to voltage sag/swell and momentary power failure.



Features

- Patent Application :
Single line dynamic voltage restorer (Application 10-2007-0076102)
- Voltage restoration(within 2ms)
- Automatic uninterruptible bypass circuit using thyristor
- Mass storage super capacitor
- Sinusoidal output
- High efficiency
- Excellent reliability
- Mass storage and minimization using super capacitor
- Sine wave with IGBT
- Compact Design

● Solution for power supply quality

- Reliability improvement
- Prevention of the malfunctions due to voltage sag and/or momentary power failure.
- Protection of the major electronic equipments sensitive to noise.

● Use of DSP

- Digital type, reliability improvement, latest algorithms
- Improved switching time and restoration speed
- Real-time control
- Real-time monitoring of voltage and current with LCD
- Recording of event history such as sag, swell, dip, etc.
- Real-time check of occurrence frequency and system condition

Applications

Loads

Computers, IT equipments, servers, automation equipments, medical equipments, semiconductor process

Systems

Single Phase, 100~120V / 200~240V

Locations

Semiconductor Plant, Data Bank, Office, Medical Center, Airport, Apartment, Factory etc.

10 Cycle Short Interruption

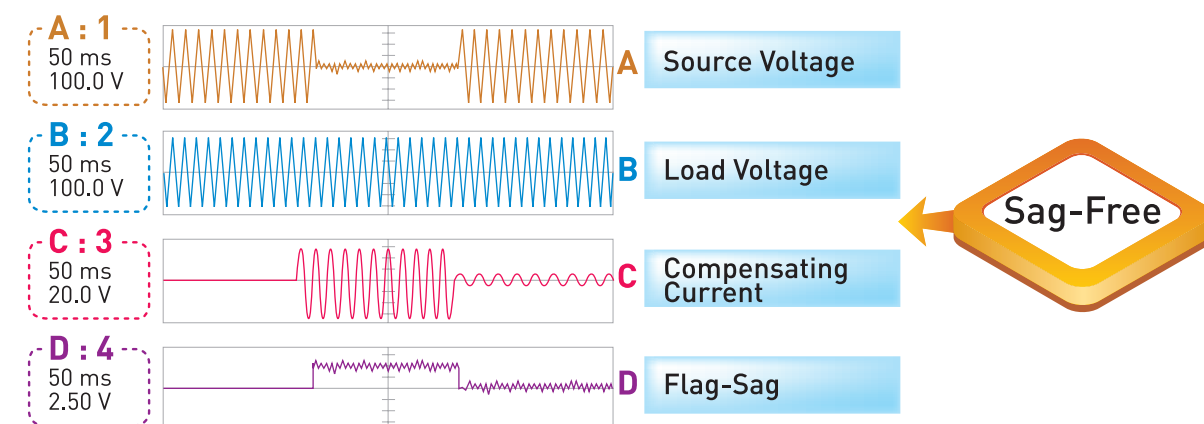

Principle of Single-phased Voltage Restorer

The voltage restorer is an equipment that employs PWM sinusoidal wave producing method using IGBT and the realtime monitoring of system voltage using DSP controller. The core portion of the equipment is composed of the super capacitor which stores energy, the thyristor bypass for switching of the system and load in case of power deterioration, the IGBT stack which produces sinusoidal wave voltage, the DSP for realtime control, and power circuit.

Voltage quality of the system is monitored in realtime. Normally, system power is supplied through thyristor bypass. In case of an accident, power source and load are switched immediately, IGBT stack produces sinusoidal wave while the load side keeps an optimum power condition.

System Configurations

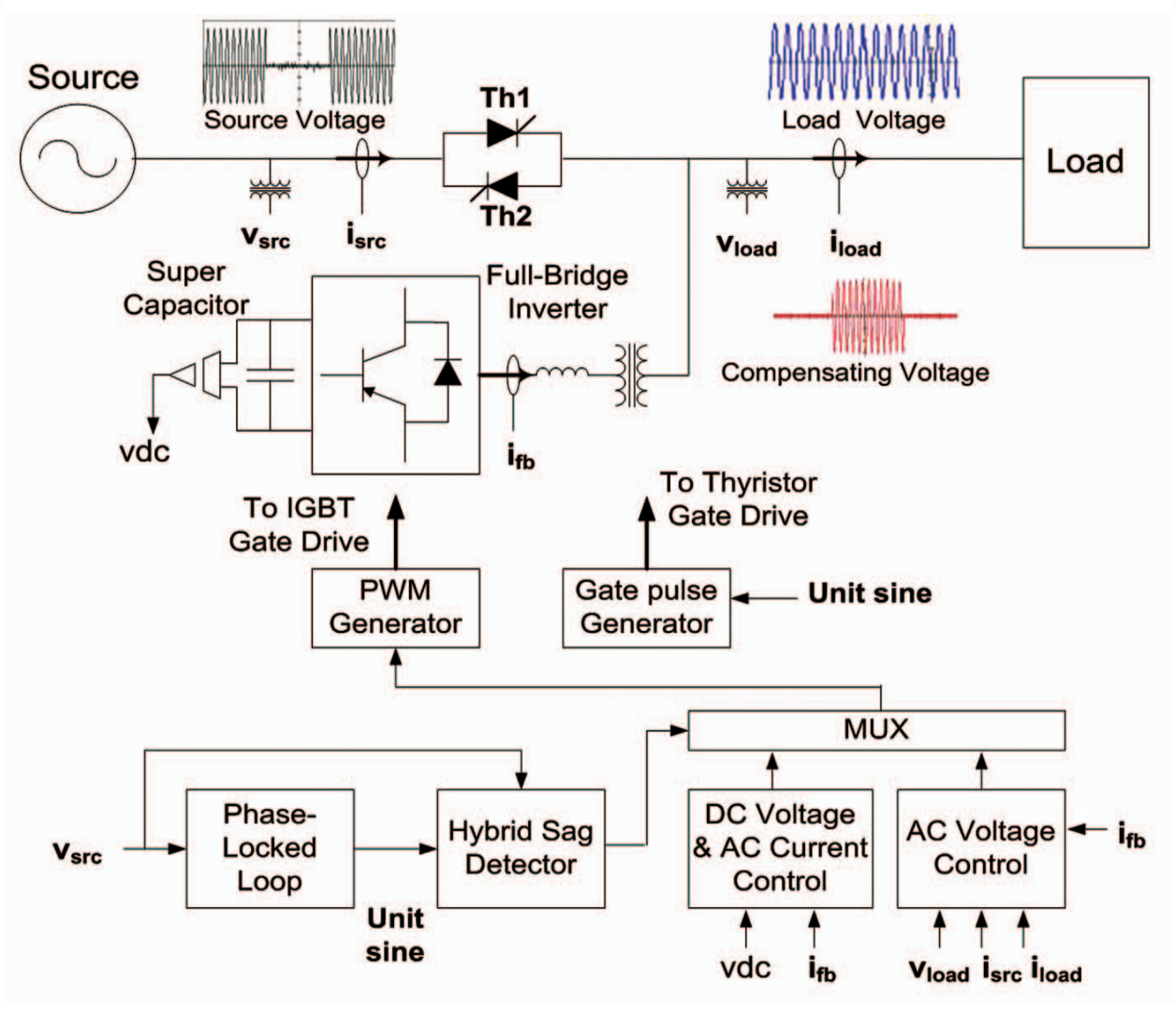

Drawing

Dimensions of SSC

Type	Rating Current[A]	Outer Dimensions[mm]		
		W	D	H
SSC 30	30	430	500	200
SSC 50	50	430	500	250
SSC 100	100	430	500	280

PSE Power System Engineering

Outline

As a growth in power control technology, demand for high-quality power supply has been increased. Heavy nonlinear loads such as inverters, rectifiers, welders, converters, and large arc furnaces could cause harmonics and/or reactive power that lead to voltage distortion and flicker. PQTech provides optimum engineering reports through investigation, analysis, model installation based on 20-years of expertise.



Field of Engineering Analysis

- Assessment of power quality
- Harmonics analysis and presentation of solutions, calculation of payback period of investment
- Harmonics design(Single tuned, High Pass)
- Furnace transformer, (high voltage)circuit breaker, controller, etc.
- Transmission System Study, Load Flow, Harmonic Current Flow, Transient Study
- Power System Engineering

Procedures of Engineering Service

- Planning of investigation
- Visit for consultation
- Measurement of power quality
- Analysis of problems
- Data analysis
- Action plan

Engineering Analysis TOOL

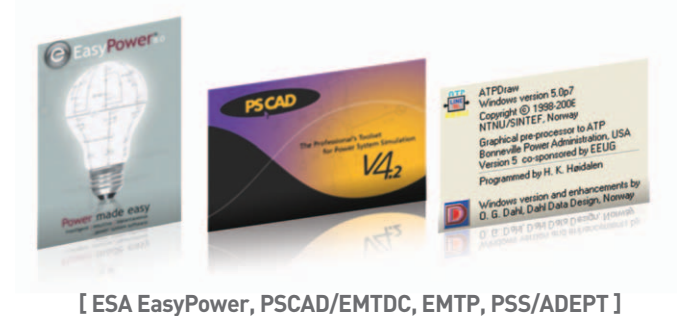

[ESA EasyPower, PSCAD/EMTDC, EMT, PSS/ADEPT]